



ATOMOS

A-EYE CAMERAS

HD-20X | 4K-12X | 4K-20X



Let's get started!

Copyright

The contents of this manual cannot be cloned, copied or translated without the permission of Atomos Global Pty.

Notice

Product specifications and information in this document are for reference only. Atomos reserves the right to change, delete, or update any content at any time and without prior notice.

FCC NOTICE (Class A)



This product complies with Part 15 of the FCC Rules. The operation is subject to the following two conditions: (1) this device may not cause harmful interference, and (2) this device must accept any interference received, including interference that may cause undesired operation.



This product has been tested and found to comply with the limits for a Class A digital device, pursuant to Part 15 of the FCC Rules. These limits are designed to provide reasonable protection against harmful interference in a residential installation. This equipment generates uses and can radiate radio frequency energy and, if not installed and used in accordance with the instructions, may cause harmful interference to radio communications. However, there is no guarantee that interference will not occur in a particular installation. If this equipment does cause harmful interference to radio or television reception, which can be determined by turning the equipment off and on, the user is encouraged to try to correct the interference by one or more of the following measures:

- Reorient or relocate the receiving antenna.
- Increase the separation between the equipment and receiver.
- Connect the equipment into an outlet on a circuit different from that to which the receiver is connected.
- Consult the dealer or an experienced radio/television technician for help.

Class A ITE

Class A ITE is a category of all other ITE which satisfies the class A ITE limits but not the class B ITE limits. Such equipment should not be restricted in its sale but the following warning shall be included in the instructions for use:



Operating this equipment in a residential environment may cause radio interference.

European Community Compliance Statement (Class A)



This product is herewith confirmed to comply with the requirements set out in the Council Directives on the Approximation of the laws of the Member States relating to Electromagnetic Compatibility Directive 2014/30/EU.

Contents

1. Safety Precautions	4
2. Packing List	4
3. Quick Start	5
4. Video Format	6
5. About Product	7
5.1 Features	7
5.2 Specifications	8
5.3 Interface and Switch	11
5.4 Dimension	11
5.5 Installation	12
5.6 Remote Control	13
6. GUI Settings	14
6.1 Menu	14
6.2 Exposure	14
6.3 Color	15
6.4 Image	15
6.5 Display	16
6.6 PTZ Setting	16
6.7 Setting	17
6.8 Version	17
6.9 Default	17
7. Web Settings	18
7.1 Access Camera	18
7.2 Camera Control	18
7.3 Video Settings	19
7.4 Image Settings	20
7.5 Audio Settings	20
7.6 System Settings	20
7.7 Network Settings	21
7.8 NDI® Settings	22
7.9 Device Information	22
7.10 Download Upgrade Program	22
8. Troubleshooting	23

1. Safety Precautions

- During the installation and use of the equipment, all electrical safety regulations of the country and region of use must be strictly observed.
- Please use the power adapter that is supplied with this product.
- Please do not connect multiple devices to the same power adapter (exceeding the capacity of the adapter may generate excessive heat or cause a fire).
- Do not rotate the camera head by hand, as it may cause mechanical failure.
- When installing this product on a wall or ceiling, secure the device securely. When installing, make sure that there are no obstacles within the rotation range of the gimbal; do not turn on the power until all installations are completed.
- To avoid heat build-up, keep ventilation around the device smooth.
- If the device emits smoke, smells, or makes noises, please turn off the power immediately and unplug the power cord, and contact the dealer in time.
- This device is not waterproof, please keep the device dry.
- This product has no user serviceable parts, damage caused by disassembly by the user is not covered by the warranty.



Specific frequencies of electromagnetic field may affect the image of the camera!

2. Packing List

Name	Quantity
Camera	1
Power Adapter	1
Power Cable	1
RS232 Cable	1
USB Cable (Optional)	1
Remote Control	1
User Manual	1

3. Quick Start

- 1) Please check connections are correct before starting.
- 2) Connect the power adapter to the power connector on the rear panel of the camera. The power indicator on the front panel of the camera should illuminate.
- 3) After the camera is powered on, it starts to initialize, right up to the limit position, and then both horizontal and vertical go to the middle position, the motor stops running, and the initialization is completed.
(Note: If preset 0 is saved, PTZ will be move to preset 0)

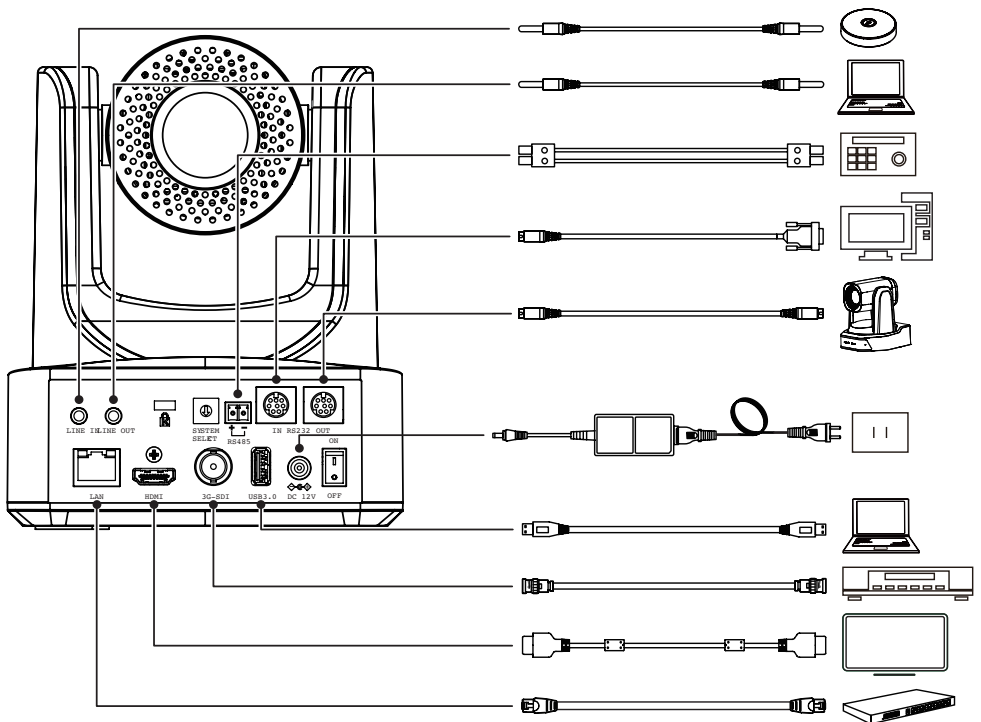

4. Video Formats

A-EYE HD 20X			
HDMI		SDI	
0	1080P60	8	-
1	1080P50	9	-
2	1080I60	A	1080P59.94
3	1080I50	B	1080I59.94
4	720P60	C	1080P29.97
5	720P50	D	-
6	1080P30	E	-
7	1080P25	F	720P59.94

A-EYE 4K 12X & 4K 20X			
HDMI		SDI	
0	1080P60	0	1080P60
1	1080P50	1	1080P50
2	1080I60	2	1080I60
3	1080I50	3	1080I50
4	1080P30	4	1080P30
5	720P60	5	720P60
6	1080P29.97	6	1080P29.97
7	1080I59.94	7	1080I59.94
8	1080P59.94	8	1080P59.94
9	720P59.94	9	720P59.94
A	4KP29.97	A	1080P29.97
B	4KP59.94	B	1080P59.94
C	4KP25	C	1080P25
D	4KP30	D	1080P30
E	4KP50	E	1080P50
F	4KP60	F	1080P60

5. Product

5.1 Features

- **60.7° Wide-angle Lens + 20x Optical Zoom (A-EYE HD 20X)**
60.7° high-quality ultra-wide-angle lens, optical zoom up to 20x, 16x digital zoom.
- **12x Optical Zoom (A-EYE 4K 12X)**
4K ultra long focal lens with high quality, 8 million ultra-high resolution, 12x optical zoom; maximum field angle is 71°.
- **20x Optical Zoom (A-EYE 4K 20X)**
4K ultra long focal lens with high quality, 8 million ultra-high resolution, 20x optical zoom, maximum field angle is 60°.
- **1080P Full HD (A-EYE HD 20X)**
1/2.8-inch high-quality HD CMOS sensor with effective 2.07 million pixels, high-quality images with a maximum resolution of 1920x1080.
- **4K UHD (A-EYE 4K 12X and 4K 20X)**
1/2.5-inch high-quality UHD CMOS sensor with a maximum of 8.51 million pixels can realize 4K (3840x2160) ultra-high-resolution high-quality images. Compatible with 1080p, 720p and other resolutions.
- **New ISP Image Processing Algorithm**
The latest generation ISP image processing algorithm provides more complete white balance and automatic exposure functions, significantly improving the image output of the camera. Widely used in education recording and broadcasting, distance education, video conferencing, live broadcasting, broadcasting and other industries.
- **Upgraded AI Technology**
Using upgraded AI technology, through face recognition, it can accurately determine the location of people, with automatic tracking and automatic frame selection.
- **NDI®HX3**
Supports NDI®HX3 technology, ultra-low latency high-quality audio and video signal transmission, and can achieve unparalleled ultra-high-resolution image quality and lossless effects that are closer to vision.
- **Leading Auto Focus Technology**
Using advanced focusing algorithm, the lens can focus quickly and accurately.
- **Audio Processing Algorithm**
Exclusive audio processing algorithm reduces environmental noise, and supports EQ adjustment to optimize sound effects; the device supports dual mic pickup, and can also be connected to external microphones etc., to meet the pickup needs of most scenarios.
- **Multiple Interfaces**
Supports HDMI and SDI interfaces; effective transmission distance of SDI is up to 150 meters (1080P30). HDMI, SDI, NET can output three HD digital signals at the same time.
- **Remote Control**
Using the RS232 and RS485 serial ports, the camera can be controlled remotely.

5.2 Specifications

	A-EYE HD 20X	A-EYE 4K 12X	A-EYE 4K 20X
Video			
Signal System	1080P60, 1080P59.94, 1080P50, 1080I60, 1080I59.94, 1080I50, 1080P30, 1080P29.97, 1080P25, 720P60, 720P59.94, 720P50	HDMI: 4KP60, 4KP50, 4KP30, 4KP25, 4KP59.94, 4KP29.97, 1080P60, 1080P50, 1080P59.94, 1080P30, 1080P29.97, 1080I60, 1080I50, 1080I59.94, 720P60, 720P59.94 3G-SDI: 1080P60, 1080P50, 1080P30, 1080P29.97, 1080P59.94, 1080P25, 1080I60, 1080I50, 1080I59.94, 720P60, 720P59.94	HDMI: 4KP60, 4KP50, 4KP30, 4KP25, 4KP59.94, 4KP29.97, 1080P60, 1080P50, 1080P59.94, 1080P30, 1080P29.97, 1080I60, 1080I50, 1080I59.94, 720P60, 720P59.94 3G-SDI: 1080P60, 1080P50, 1080P30, 1080P29.97, 1080P59.94, 1080P25, 1080I60, 1080I50, 1080I59.94, 720P60, 720P59.94
Sensor	1/2.8 inch, CMOS, Effective pixels: 2.07M	1/2.5 inch, CMOS, Effective pixels: 8.51M	1/1.8 inch, CMOS, Effective pixels: 8.42M
Scanning Mode	Progressive		
Lens	20x, f = 4.42mm ~ 88.5mm, F1.8 ~ F2.8	12x, f = 4.4mm ~ 52.8mm, F1.8 ~ F2.6	20x, f=6.25mm~125mm, F1.58~F3.95
Digital Zoom	16x		
Minimum Illumination	0.5 Lux @ (F1.8, AGC ON)		
Shutter	1/30s ~ 1/10000s		
White Balance	Auto, VAR, Manual, One Push, Indoor, Outdoor		
Backlight Compensation	Support		
Digital Noise Reduction	2D & 3D Digital Noise Reduction		
SNR	0.5 Lux @ (F1.8, AGC ON)		
Horizontal FOV	60.7° ~ 3.36°	71° ~ 8.2°	60°~3.5°
Vertical FOV	34.1° ~ 1.89°	42.7° ~ 4.5°	35.7°~2.0°
Pan Angle	±170°		
Tilt Angle	-30° ~ +90°		
Pan Speed	1.7° ~ 100°/s		
Tilt Speed	1.7° ~ 69.9°/s		
Image Flip	Support		
Image Freeze	Support		
Preset Position	255		
Preset Accuracy	0.1°		
PoE	Support		

5.2 Specifications

A-EYE HD 20X		A-EYE 4K 12X	A-EYE 4K 20X
Audio			
Microphone Array	Built-in dual microphones, 100Hz to 16KHz frequency response	No Built-in Mic	
Audio Input	Support LINE IN audio input		
Audio Output	Support LINE OUT, HDMI, USB and other audio output		
USB			
Operate System	Windows 7/8/10, Mac OS X, Linux, Android, iOS, iPadOS		
Color System/Compression	YUY2/MJPEG/H.264	YUY2/H.264/MJPEG/H.265	
Video Format	YUY2: max to 1080P@5fps H.264 AVC: max to 1080P@30fps	YUY2: max to 1080P@5fps H.264 AVC: max to 2160P@30fps H.265 HEVC: max to 2160P@30fps MJPEG: max to 2160P@30fps	
USB Audio	Support		
USB Video Protocol	UVC 1.1/UVC 1.5		
UVC PTZ Control	Support		
Network			
Video Compression	H.264/H.265	H.264/H.265/MJPEG	
Video Stream	First Stream, Second Stream		
First Stream Resolution	1920x1080, 1280x720, 1024x576, 960x540, 640x480, 640x360	3840x2160, 1920x1080, 1280x720, 1024x576, 720x480, 720x408, 640x480, 640x360	
Second Stream Resolution	1280x720, 1024x576, 720x480, 640x360, 480x272, 320x240, 320x180	720x480, 720x408, 640x480, 640x360, 480x320, 320x240	
Video Bit Rate	32Kbps ~ 20480Kbps	First Stream: 32kbps~51200kbps Second Stream: 32kbps~20480kbps	
Bit Rate Control	CBR, VBR		
Frame Rate	1fps ~ 60fps	50Hz: 1fps ~ 50fps 60Hz: 1fps ~ 60fps	
Audio Compression	AAC		
Audio Bit Rate	96Kbps, 128Kbps, 256Kbps		
Protocols	NDI HX3, TCP/IP, HTTP, RTSP, RTMP/RTMPS, ONVIF, DHCP, SRT, Multicast		

5.2 Specifications

	A-EYE HD 20X	A-EYE 4K 12X	A-EYE 4K 20X
Input/Output Interfaces			
LINE IN Interface	1 x LINE IN: 3.5mm Audio Interface		
LINE OUT Interface	1 x CVBS: 3.5mm Audio Interface		
Communication Interface	1 x RS485: 2pin phoenix port, Max Distance: 1200m, Protocol: VISCA/Pelco-D/Pelco-P		
	1 x RS232 IN: 8pin Min DIN, Max Distance: 30m, Protocol: VISCA/Pelco-D/Pelco-P		
	1 x RS232 OUT: 8pin Min DIN, Max Distance: 30m, Protocol: VISCA network use only		
Network Interface	1 x NET: 10M/100M Adaptive Ethernet Port		
USB Interface	1 x USB 2.0: Type A		
SDI Interface	1 x 3G-SDI: BNC type, 800mVp-p, 75Ω. Along to SMPTE 424M standard		
HDMI Interface	1 x HDMI: Version 1.3		
Power Jack	JEITA type (DC IN 12V)		
Physical Specifications			
Input Voltage	DC 12V/PoE+(802.3at)		
Input Current	Max. 1.2A	Max. 2A	
Operating Temperature	0°C ~ 40°C		
Storage Temperature	-40°C ~ 60°C		
Power Consumption	Max. 15W	18W (max.)	
Dimension (mm)	176.5 x 139.2 x 165.8	169mm x 146mm x 168mm	
Net Weight	About 1.5Kg	About 1.6Kg	
Tally Indicator	1		
Power Indicator	1		
Status Indicator	1		
Restore Key	1		

5.3 Interface and Switch

Item	Description
1	LINE IN Interface
2	LINE OUT Interface
3	System Select Switch
4	RS485 Interface
5	RS232 IN Interface
6	RS232 OUT Interface
7	LAN Interface
8	HDMI Interface
9	SDI Interface
10	USB 3.0 Interface
11	DC 12V Interface
12	Power Switch

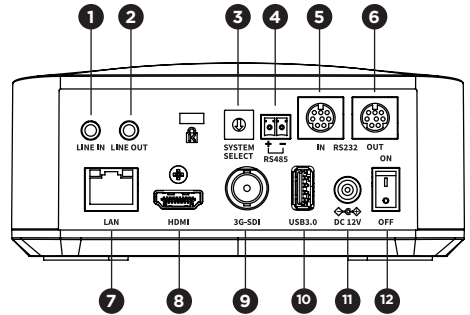

5.4 Dimensions

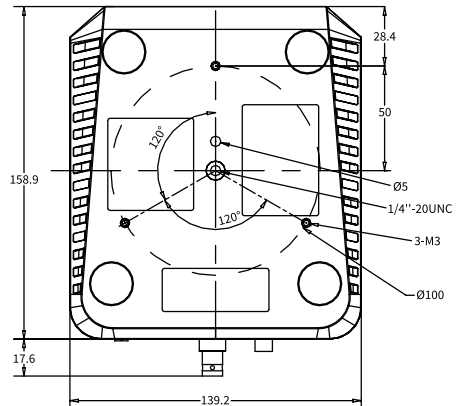
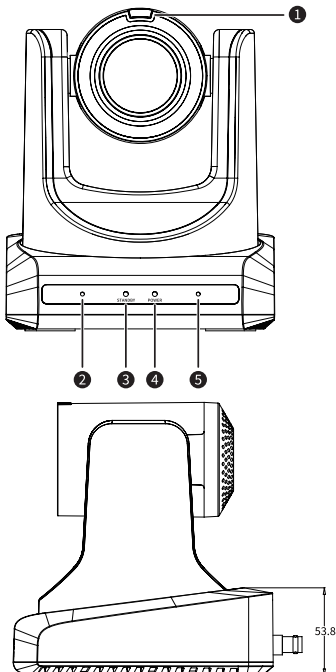

5.5 Installation

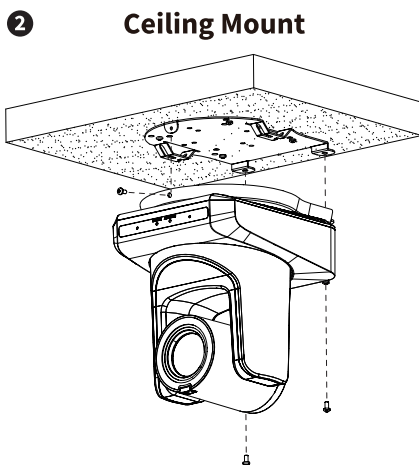
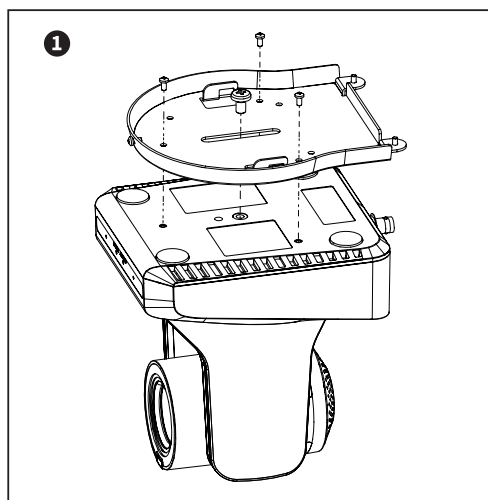
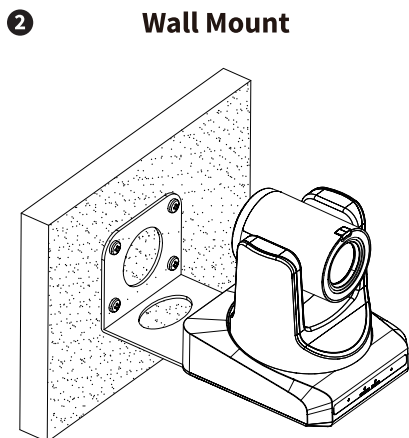
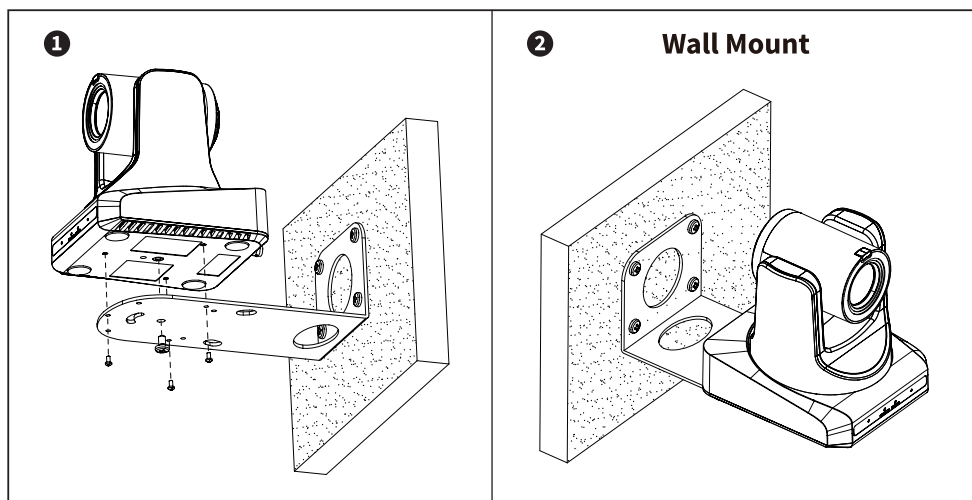

The installation diagram is for reference only. The brackets and screws are not supplied.

For packing accessories, please refer to the actual product.

5.6 Remote control

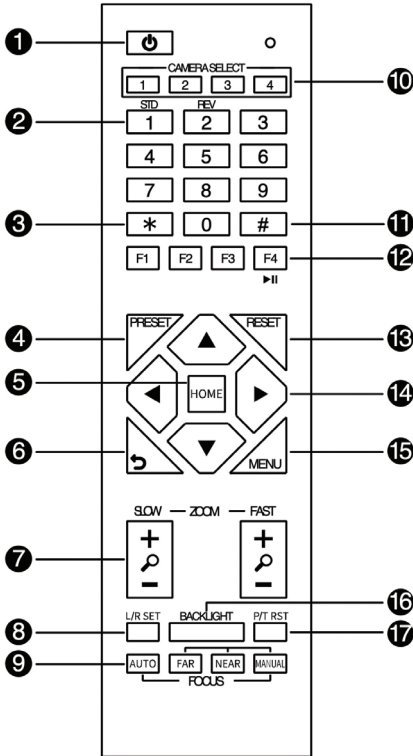

1. Standby Key

Press to enter standby mode

2. Number Key

Press to set preset or call preset

3 * Key

Use with other keys

4. PRESET Key

Set preset: [PRESET] + Number key (0-9)

5. HOME Key

Confirm selection or press to turn PTZ back to the middle position

6. Return Key

Press to return to the previous menu

7. ZOOM Key

- SLOW: Zoom In [+] or Zoom Out [-] slowly
- FAST: Zoom In [+] or Zoom Out [-] fast

8. L/R SET Key

- Standard: Simultaneously press L/R SET + 1
- Reverse: Simultaneously press L/R SET + 2

9. FOCUS Key

Auto/Manual/Far/Near focus

10. CAMERA SELECT Key

Press to select and control the camera

11. # Key

Use with other keys

12. IR Remote Control Key

- []+[#]+[F1]: Address 1
- []+[#]+[F2]: Address 2
- []+[#]+[F3]: Address 3
- []+[#]+[F4]: Address 4

13. RESET Key

Clear preset position: [RESET] + Number key (0-9)

14. PTZ Control Key

PTZ moved according to the arrow indicates

15. MENU Key

Press to enter or exit OSD Menu

16. BACKLIGHT Key

Backlight ON/OFF: Press repeatedly to enable or disable the backlight compensation.

NOTE:

- Effective only in auto exposure mode.
- If there is a light behind the subject, the subject will become dark, press the backlight key to enable the backlight compensation. Press again to disable this function.

17. P/T/RST (PTZ Reset) Key

PTZ starts to self-test after pressed it

Shortcut Set

- [*]+[#]+[1]: OSD menu default English
- [*]+[#]+[3]: OSD menu default Chinese
- [*]+[#]+[4]: Display current IP address
- [*]+[#]+[6]: Quickly recover the default
- [*]+[#]+[8]: View the camera version
- [*]+[#]+[9]: Quickly set up inversion
- [*]+[#]+[MANUAL]: Restore default IP address.

6. GUI Settings

6.1 Menu

Press [MENU] key to display the main menu on the normal screen, using arrow key to move the cursor to the item to be set. Press the [HOME] key to enter the corresponding sub-menu.

Menu	
ENG/中文	ENG
AI MODE	Off
Video Format	1080P60
Style	Default
Exposure	→
Color	→
Image	→
Display	→
PTZ Setting	→
Setting	→
Version	→
Default	→

[MENU] Return / [HOME] Enter

ENG/中文: ENG, 中文.

AI Mode: Off, Single Track, Frame Track, Demo Mode.

Video Format: 1080P60, 1080P50, 1080I60, 1080I50, 1080P30, 1080P25, 720P60, 720P50.

Style: Default, Cold, Warm, Clear, Soft, User1, User2, User3.

6.2 Exposure

Move the main menu cursor to [Exposure], and press [HOME] key enter the exposure page, as shown in the following figure.

Exposure		
→	AE	Auto
	Flicker	50Hz
	Expcomp Mode	On
	Expmode	2
	Backlight	Off
	Gain Limit	15
	DRC Mode	Off

[MENU] Return / [HOME] Enter

AE: Auto, Manual, Iris Priority, Shutter Priority, Bright Priority.

Flicker: Off, 50Hz, 60Hz (Effective only in Auto, Iris Priority, Bright Priority mode).

Expcomp Mode: On, Off (Effective only in Auto, Iris Priority mode).

Expmode: -7~7 (Effective only in Expcomp Mode to On).

Backlight: On, Off (Effective only in Auto, Iris Priority mode).

Bright: 0~99 (Effective only in Bright Priority mode).

Gain Limit: 0~32 (Effective only in Auto, Iris Priority, Bright Priority mode).

Iris: F1.8, F2.0, F2.4, F2.8, F3.4, F4.0, F4.8, F5.6, F6.8, F8.0, F9.6, F11, Off (Effective only in Manual, Iris Priority mode).

Shutter: 1/30, 1/50, 1/60, 1/90, 1/100, 1/125, 1/180, 1/250, 1/350, 1/500, 1/725, 1/1000, 1/1500, 1/2000, 1/3000, 1/4000, 1/6000, 1/10000 (Effective only in Manual, Shutter Priority mode).

Gain: 0~31 (Effective only in Manual, Shutter Priority mode).

DRC Mode: Manual, Auto, Off.

DRC: 0~14 (Effective only in DRC Mode to Manual).

6.3 Color

Move the main menu cursor to [Color], and press [HOME] key enter the color page, as shown in the following figure.

Color		
→	AWB	Auto
	Sens	Low
	R-Tuning	0
	B-Tuning	0
	Hue	50
	Saturation	100
[MENU] Return / [HOME] Enter		

AWB: Auto, VAR, Manual, One Push, Indoor, Outdoor.

Sens: Low, Middle, High.

R-Gain: 0~1023 (Effective only in Manual, One Push mode).

B-Gain: 0~1023 (Effective only in Manual, One Push mode).

R-Tuning: -128~128 (Effective only in Auto, Temp, One Push mode).

B-Tuning: -128~128 (Effective only in Auto, Temp, One Push mode).

Hue: 0~99.

Saturation: 0~200.

Temp: 2000 ~ 8500 (Effective only in Temp mode).

6.4 Image

Move the main menu cursor to [Image], and press [HOME] key enter the image page, as shown in the following figure.

Image		
→	Brightness	50
	Contrast	50
	Sharpness Mode	Auto
	Gamma Mode	Manual
	Gamma	Ext
	NR-2D Mode	Auto
	NR-3D Mode	Auto
[MENU] Return / [HOME] Enter		

Brightness: 0~99.

Contrast: 0~99.

Sharpness Mode: Manual, Auto.

Sharpness: 0~25 (Effective only in Sharpness Mode to Manual).

Gamma Mode: Manual, Auto.

Gamma: Ext, 0.45, 0.5, 0.54, 0.56, 0.63 (Effective only in Gamma Mode to Manual).

NR-2D Mode: Manual, Auto.

NR-2D: 0~99 (Effective only in NR-2D Mode to Manual).

NR-3D Mode: Manual, Auto.

NR-3D: 0~15 (Effective only in NR-3D Mode to Manual).

6.5 Display

Move the main menu cursor to [Display], and press [HOME] key enter the display page, as shown in the following figure.

Display		
→	OSD-Dir	0
	Frac Rate	Off
	HDMI Mode	HDMI
	SDI Mode	Level A
	Flip-H	Off
	Flip-V	Off
	Freeze	Off
[MENU] Return / [HOME] Enter		

OSD-Dir: 0, 90, 180, 270.

Frac Rate: On, Off.

HDMI Mode: HDMI, DVI.

SDI Mode: Level A, Level B.

Flip-H: On, Off.

Flip-V: On, Off.

Freeze: On, Off.

6.6 P/T/Z Setting

Move the main menu cursor to [P/T/Z Setting], and press [HOME] key enter the P/T/Z setting page, as shown in the following figure.

P/T/Z Setting		
→	AF-Sense	High
	AF-Zone	Front
	Focus Limit	Off
	LR Mode	STD
	Motion Sync	Off
	Horizontal Speed	23
	Vertical Speed	19
	Zoom Speed	7
	PTbyZoom	On
[MENU] Return / [HOME] Enter		

AF-Sense: High, Normal, Low.

AF-Zone: Front, Top, Center, Bottom.

Focus Limit: On, Off.

Near Focus Limit: 1M, 1.5M, 2M, 3M, 4M, 5M, 6M, 8M, 10M, 15M, 20M (Effective only in Focus Limit to On).

Far Focus Limit: 15M, 20M, Infinity (effective only in Focus Limit to On).

LR Mode: STD, REV.

Motion Sync: On, Off.

Horizontal Speed: 0~23.

Vertical Speed: 0~19.

Zoom Speed: 0~7.

PTbyZoom: On, Off.

6.7 Settings

Move the main menu cursor to [Setting], and press [HOME] key enter the setting page, as shown in the following figure.

Setting		
→	Visca Addr	1
	Visca Mode	Series
	Baud Rate	9600
	DHCP	Off
	IP Addr	192.168.100.88
	MAC	d4e08e548d13
[MENU] Return / [HOME] Enter		

Visca Addr: 1~7 (Effective only in VISCA protocol).

Visca Mode: Serial, Paral.

Baud Rate: 2400, 4800, 9600, 19200, 38400, 57600, 115200.

DHCP: On, Off.

IP Addr: 192.168.100.88.

MAC: d4e08e548d13.

6.8 Version

Move the main menu cursor to [Version], and press [HOME] key to enter the version page, as shown in the following figure.

Version	
Main	X8.02.15
AF	14.04.04
Date	2022-08-18
Code	VF1
NDI License	Okay
[MENU] Return / [HOME] Enter	

Main: Display the version number of the main program of the camera.

AF: Display the camera autofocus version number.

Date: Display the burning date of the main program version of the camera.

Code: Display the camera code.

NDI License: Display NDI license verification.

6.9 Default

Move the main menu cursor to [Default], press [HOME] key enter default page, as shown in the following figure.

Default		
→	Reset	No
[MENU] Return / [HOME] Enter		

Reset: Yes, No.



GUI menu and parameters are subject to change without notice.

7.0 Web Settings

7.1 Access Camera

Access <http://192.168.100.88> to pop up the login window, then input username (default: admin) and password (default: admin). After login, it will show as below:



7.2 Camera Control

All pages include two menu bars:

Real time monitoring: displaying video image

Parameter setup: with function buttons.

A. Video Viewing Window

Video viewing window must be same as video resolution, the bigger the resolution, the bigger the playing area. Double-click the viewing window to display full-screen; double-click again to return to previous size.

Status bar in viewing window shown as below:

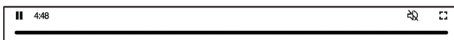

- 1) **Video playback pause button:** control real-time video pause, stop the last picture, click recoverable video again.
- 2) **Audio control buttons:** can adjust the volume or set silent mode.
- 3) **Full screen switch button.**

B. PTZ Setup

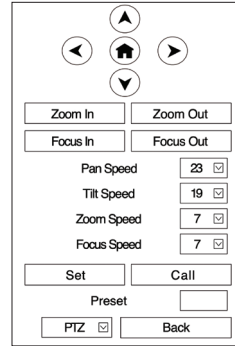

1) Pan and Tilt Control

Up, Down, Left and Right arrows and the home button allow you to manually move the camera to the desired position.

2) Zoom

Zoom In and Zoom Out buttons.

3) Focus

Focus In and Focus Out buttons allow for fine manual focus adjustment if the camera has any problems auto focusing.

4) PTZ Speeds

Pan speed can be set at any rate between 1 ~ 24, Tilt speed can be set at any rate between 1 ~ 20. Zoom and Focus speeds can be set at any rate between 1 ~ 7.

5) PTZ Presets

To set up a camera position that you would like to return to later, you can save presets. Type a number between 0 and 254 into the Preset box. Click the "Set" button to save the current location with that preset number. Click the "Call" button to cause the camera to return to that position. This enables smooth, quick and convenient control without the need to manually drive the camera.

Method: Type preset number into the Preset box
Preset: Optional items: 0 ~ 254.



6) PTZ/OSD Dropdown

From the dropdown menu, clicking the OSD option will open the on-screen display menu of the camera giving you control from within the IP interface.

7) Language Selection

Click either "Chinese", "English" or "Russian" to change the language of the webpage.

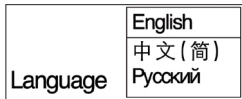

7.3 Video settings

Video Settings

Frac Rate On Off

First stream

Encode Level:

Encode Protocol:

Resolution:

Bit Rate:

Frame Rate:

I Key Frame Interval:

Bit Rate Control:

Slice Split Enable:

Slice Size:

Second stream

Encode Level:

Encode Protocol:

Resolution:

Bit Rate:

Frame Rate:

I Key Frame Interval:

Bit Rate Control:

Slice Split Enable:

Slice Size:

1) Frac Rate

Turn On/Off Frac Rate.

2) Encode Level

Support baseline, mainprofile, highprofile and svc-t four levels.

3) Encode Protocol

Support H.264 and H.265 protocols.

4) Resolution

First stream support 1920x1080, 1280x720, 1024x576, 960x540, 640x480, 640x360. Second stream support 1280x720, 1024x576, 720x480, 640x360, 480x272, 320x240, 320x180; The higher the resolution, the clearer the image, but more network bandwidth will be required.

5) Bit Rate

The user can specify the bit rate. Generally speaking, the higher the bit rate, the clearer of the image. However, the bit rate needs to be determined according to the network bandwidth available.

6) Frame Rate

The user can specify the size of the frame rate, generally, the higher the frame rate, the smoother the image; same bandwidth restrictions as above.

7) I Key Frame Interval

Set interval between 2 I frame, the greater the interval the poorer the playback in the viewing window.

8) Bit Rate Control

CBR (Constant Bit Rate): Video is encoded according to a preset data rate. VBR (Variable Bit Rate): Video encoding data rate is adjusted for the best image quality.

9) Slice Split Enable

Enable or disable slice split function.

10) Slice Size

Set the size of slice.

7.4 Image settings

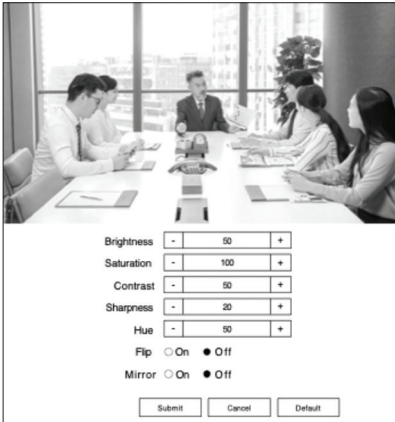

1) Brightness

Brightness of image: 0~99 (Default value is 50).

2) Saturation

Saturation of image: 0~200 (Default value is 100).

3) Contrast

Contrast of image: 0~99 (Default value is 50).

4) Sharpness

Sharpness of image: 0~99 (Default value is 20).

5) Hue

Hue of image: 0~99 (Default value is 50).

6) Flip

Turn On/Off the Flip function.

7) Mirror

Turn On/Off the Mirror function.

7.5 Audio settings

Audio Settings

Audio Switch

Audio Type

Sample Rate

Bit Rate

Input Type

Input Vol L

Input Vol R

1) Audio Switch

Turn On/Off audio switch.

2) Audio Type

Optional items: AAC.

3) Sample Rate

Optional items: 32K, 48K.

4) Bit Rate

Optional items: 96K, 128K, 256K.

5) Input Type

Optional items: LINE IN, MIC.

6) Input Vol L

The volume of the left channel.

7) Input Vol R

The volume of the right channel.

7.6 System settings

Initialize

Reboot

User

UserName

Password

Guest

Password

1) Reboot

Click the "Reboot" button, system restart.

2) Username and Password

The user can modify the password (letters and numbers only).

7.7 Network settings

Lan Settings

IP Configuration Type

IP Address

Subnet Mask

Gateway

DNS Address

MAC Address

NTP Settings

Time Zone

Server Address

Time Show On Off

Position

Subtitle Display On Off

Subtitle Content

Port Settings

HTTP Port

RTSP Port

TCP Port

UDP Port

Sony Visca

RTMP(S) Settings

First Stream On Off

MRL

Second Stream On Off

MRL

SRT Settings

SRT On Off

SRT Port

SRT Encryption

SRT Password

RTSP Settings

RTSP Auth On Off

ONVIF Settings

ONVIF On Off

ONVIF Auth On Off

1) Lan Settings

Default IP address is 192.168.100.88, the MAC address cannot be modified.

2) NTP Settings

Setting NTP Time Zone and Server Address. Turn On/Off Time Show, set the position of the Time Show. Turn On/Off Subtitle Display, set the Subtitle Content of the camera screen.

3) Port Settings

A. HTTP Port

IP address identifies network device, the device can run multiple web applications, each network program using network port to transmit data, so data transmission to be carried out between the port and port. Port setting is to set up web server program using which port to transmit. When port mapping, need to be consistent with the port number (default port: 80).

B. RTSP Port

The camera support RTSP protocol, use the VLC tools broadcast, default port: 554.

C. TCP Port

Support TCP connection then control camera, default port: 5678.

D. UDP Port

Support UDP protocol, default port: 1259.

E. Sony Visca

Support Sony Visca, default value: 52381.

4) RTMP(S) Settings

Turn On/Off first stream or second stream, setting the MRL of RTMP.

5) SRT Settings

Turn On/Off SRT, Setting the SRT Port, SRT Encry and SRT Password.

6) RTSP Settings

Turn On/Off RTSP Auth.

7) ONVIF Settings

Turn On/Off ONVIF and ONVIF Auth.

7.8 NDI® HX3 Settings

1) NDI® HX3

NDI Settings

NDI On Off

NDI License

Server IP

Group Name

Key

NDI Firmware Version

Turn On/Off NDI® HX3.

2) NDI® License

Display NDI License verification results.

3) Server IP

Setting NDI® Server IP address.

4) Group Name

Setting NDI® Group Name.

5) Key

Setting NDI® Key.

6) NDI® Firmware Version

Display NDI® Firmware Version.

7.9 Device information

Information

Device ID

Device Type

Software Version

Webware Version

Device Serial Number

7.10 Download upgrade program

Download the latest firmware by visiting atomos.com/support



Web interface and parameters are subject to change without notice.

8 Troubleshooting

Image

- **The monitor shows no image**

- 1) Check that the camera power supply is connected, the voltage supply is correct, and the power indicator light is on.
- 2) Turn off the power switch and check whether the camera performs a self-test.
- 3) Check the video input cable.

- **Video image displayed is jittery**

- 1) Check whether the camera installation is stable.
- 2) Check whether there is vibrating machinery or object near the camera.

- **Unable to access camera via browser**

- 1) Disconnect the network, connect camera and PC separately, and reset the IP address of PC.
- 2) Check IP address, subnet mask, and gateway settings of the camera.
- 3) Check whether there is a conflict with the MAC address.
- 4) Check whether the web port has been modified. The default web port is 80.

- **Forgotten IP address or login password**

Default IP address: 192.168.100.88

Default user name: admin

Default password: admin

Control

- **Remote control does not work**

- 1) Check and replace the battery for the remote controller.
- 2) Check whether the camera working mode is correct.
- 3) Check whether the address of remote control matches the camera.

- **Serial port does not control**

- 1) Check whether the camera protocol, address and baud rate are the same.
- 2) Check whether the control cable is connected securely.

- 3) Check whether the address of remote control matches the camera.

- **Serial port does not control**

- 1) Check whether the camera protocol, address and baud rate are the same.
- 2) Check whether the control cable is connected securely.

Product Registration

To register your A-EYE CAMERA, visit:

my.atomos.com/account

Support

If you experience any issues using your A-EYE CAMERA or have an unanswered question don't hesitate to reach out.

atomos.com/support

Before attempting to use this product, please read this instruction manual thoroughly and keep it safe for future reference. Specifications are subject to change without notice.